



# MODEL T10001 5 Shelf Unit INSTRUCTION SHEET

## Specifications

Overall Size ..... 28½"W x 10½"D x 71"T  
Shelf Size ..... 28¼"W x 10¼"D  
Number of Shelves..... 5

## Inventory

Qty

- A. Support Bracket ..... 8
- B. Nut..... 56
- C. Bolt ..... 56
- D. Rail ..... 4
- E. Shelf ..... 5
- F. Foot ..... 4

## Assembly

After unpacking your Model T10001 shelving unit, perform an inventory of the parts. You will need a #3 Phillips screwdriver and a 10mm wrench to assemble the shelves.

Begin by loosely assembling the shelf unit with the supplied nuts and bolts. Attach one side of the rails, then the other, making sure that the shelves are parallel to one another as shown in the illustration on **Page 2**. Once the shelf unit is assembled, attach the feet and place it upright on a flat level surface, then tighten all of the bolts.



*If you need help with your new item, call our Tech Support at: (570) 546-9663.*

COPYRIGHT © SEPTEMBER, 2007 BY GRIZZLY INDUSTRIAL, INC.

**WARNING: NO PORTION OF THIS MANUAL MAY BE REPRODUCED IN ANY SHAPE OR FORM WITHOUT THE WRITTEN APPROVAL OF GRIZZLY INDUSTRIAL, INC.**

#TJ9998 PRINTED IN CHINA

# T10001 Parts Breakdown and List

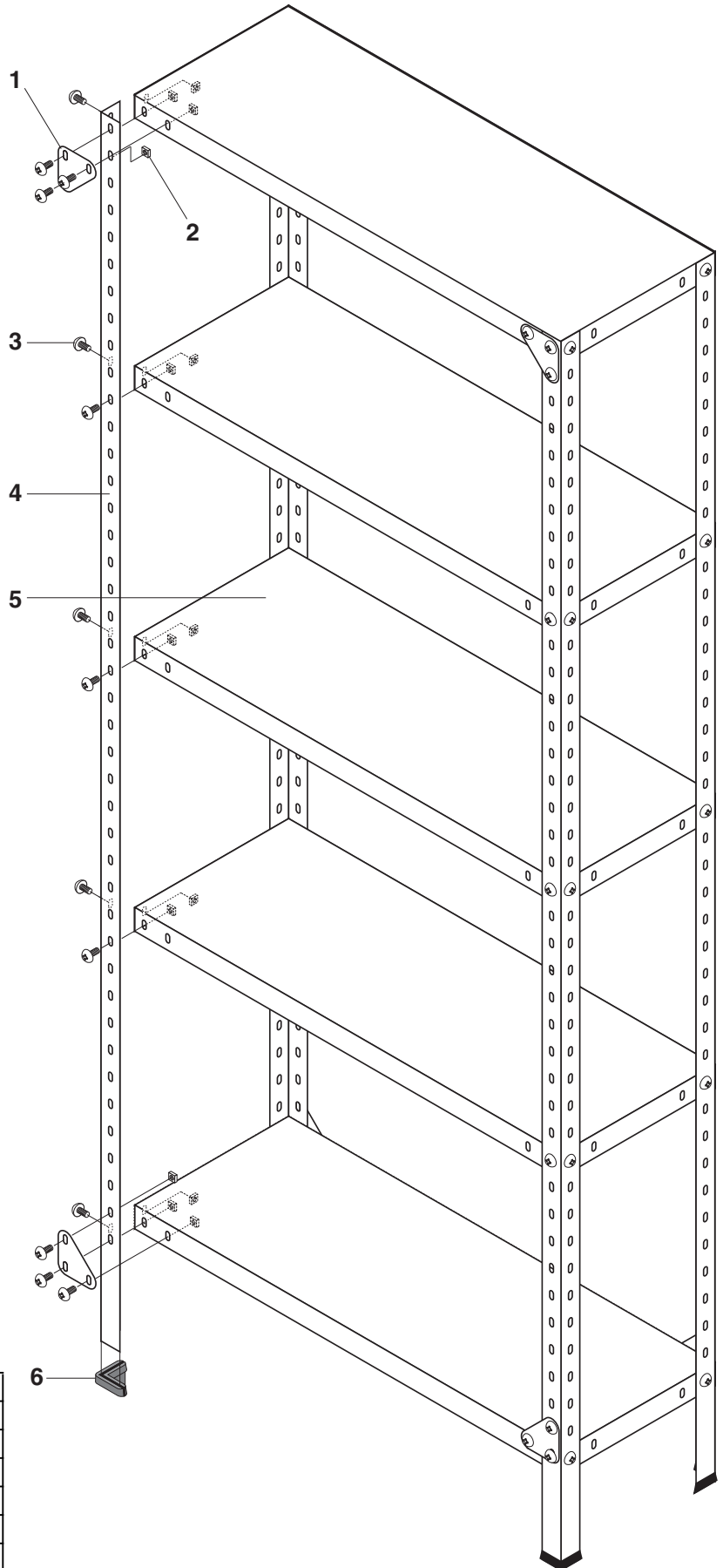
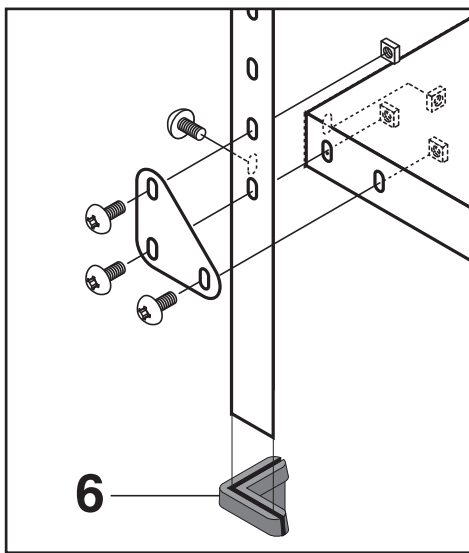
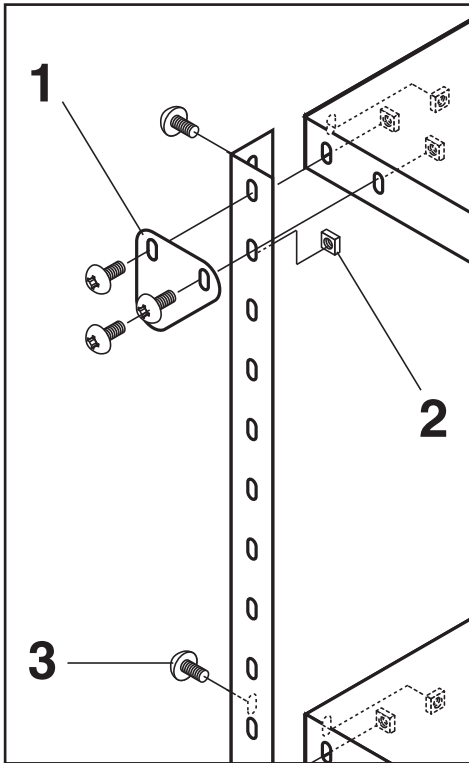

## T10001 Parts List

REF	PART #	DESCRIPTION
1	PT10001001	SUPPORT BRACKET
2	PSN02M	SQUARE NUT M6-1
3	PS68M	PHLP HD SCR M6-1 X 10
4	PT10001004	RAIL
5	PT10001005	SHELF
6	PT10001006	FOOT
7	PT10001007	COMPLETE HARDWARE BAG

